

PALLET FORKS

MULTIFIT SKID STEER LOADER

DIGGA

Digga Pallet Forks - The safest on the market

Unique to Digga, new floating tyne design with lockable tyne position offers unrivalled Australian made quality and safety for multifit skid steer loaders. Available in 1500kg and 1800kg lifting capacities

Safety guard folds down for compact storage

Machine Entry Step
Can be mounted on either side

TYNE BAR LOCKING SYSTEM

Easy width adjustment with lockable tyne positions
(PATENT PENDING)

Tynes load rating tested to ISO 2330 Standards

Heavy duty, Quality Australian made frame with added stability for easy connection to your machine.

FLOATING TYNE DESIGN

A floating tyne design offers unparalleled safety for skid steer loaders. Unlike forklifts, skid steers are able to crowd their pickup past horizontal allowing the machine to be placed in an unsafe position which could cause it to tip over. Digga's pallet fork design allows the tynes to swing freely from a single fixed point ensuring load and operator safety. Furthermore the design prevents the machine's weight to be placed on the tynes which could cause them to break.

FIXED TYNE PALLET FORKS

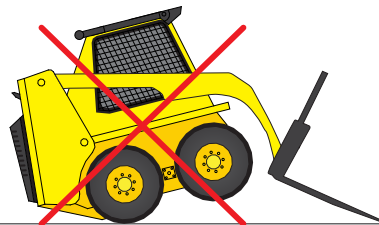

DIGGA FLOATING PALLET FORKS

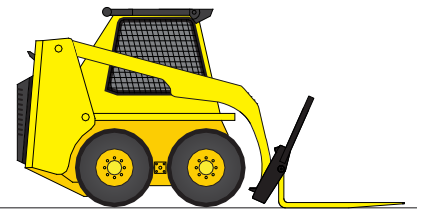

IF YOU CARE ABOUT SAFETY THEN A FLOATING TYNE DESIGN IS THE ONLY SAFE CHOICE FOR SKID STEER LOADERS

Contact your local professional dealer or contact Digga direct

THE BEST DOWNUNDER

PHONE: 1300 2 DIGGA EMAIL: info@digga.com WEB: www.digga.com

DIGGA

QLD, NT
4 Octal Street
Yatala QLD 4207

NSW, ACT
Unit 2, 36 Bluett Drive
Smeaton Grange NSW 2567

VIC, SA, TAS
27 Metcalf Street
Dandenong VIC 3175

WA
6/15 Yampi Way
Willetton WA 6155

AUTHORISED
DIGGA DEALER

Packaging

Designed for easy handling, shipping and storage. Assembly is simple and quick.



Box Measurements

1500kg - 1270L x 265W x 645H

1800kg - 1330L x 260W x 650H

Specifications

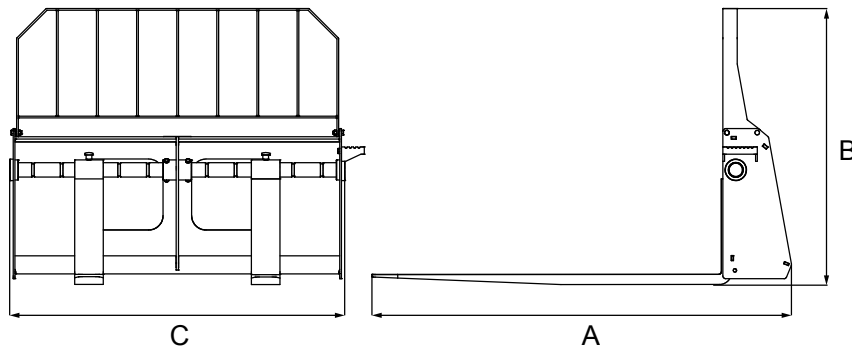

Specifications	1500kg	1800kg
Length (A)	1314mm	1464mm
Height (B)	964mm	964mm
Width (C)	1170mm	1170mm
Weight	138kg	157kg

Machine Suitability

This model suits multifit skid steer loaders only. A similar pallet fork design for other machines pickups is available. Please ask Digga for more information.

Contact your local professional dealer or contact Digga direct

THE BEST DOWNUNDER

DIGGA

PHONE: 1300 2 DIGGA EMAIL: info@digga.com WEB: www.digga.com

QLD, NT
4 Octal Street
Yatala QLD 4207

NSW, ACT
Unit 2, 36 Bluett Drive
Smeaton Grange NSW 2567

VIC, SA, TAS
27 Metcalf Street
Dandenong VIC 3175

WA
6/15 Yampi Way
Willetton WA 6155

AUTHORISED
DIGGA DEALER